

32A



32B



32C



32D



32E



32F



AM

32A Rear axle left trailing arm

32B Brake dust shield

32C Caliper mounting bracket

32D Handbrake cable holder

32E Brake hydraulic hose holder

32F Brake hydraulic hose holder

AM M1,7 x3mm (x6)

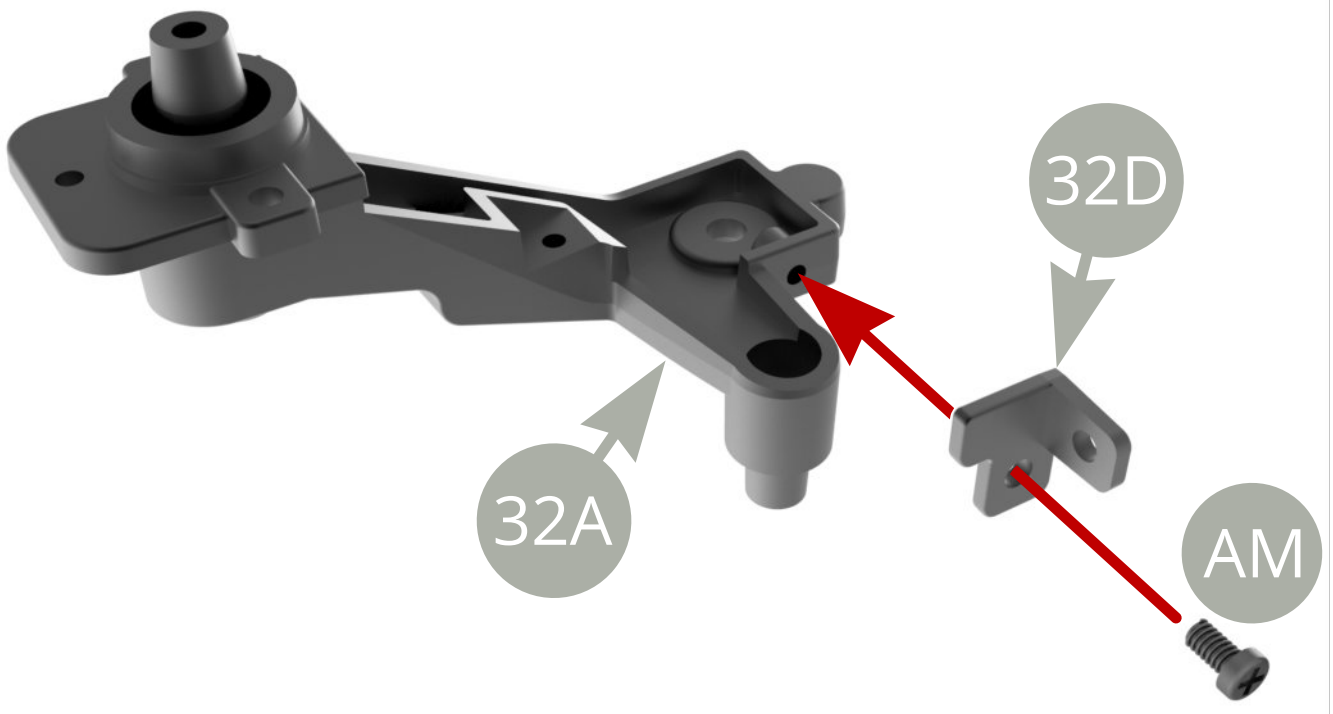

Fit **32D Handbrake cable holder** to **32A Rear axle left trailing arm** and fix with **AM screw** .

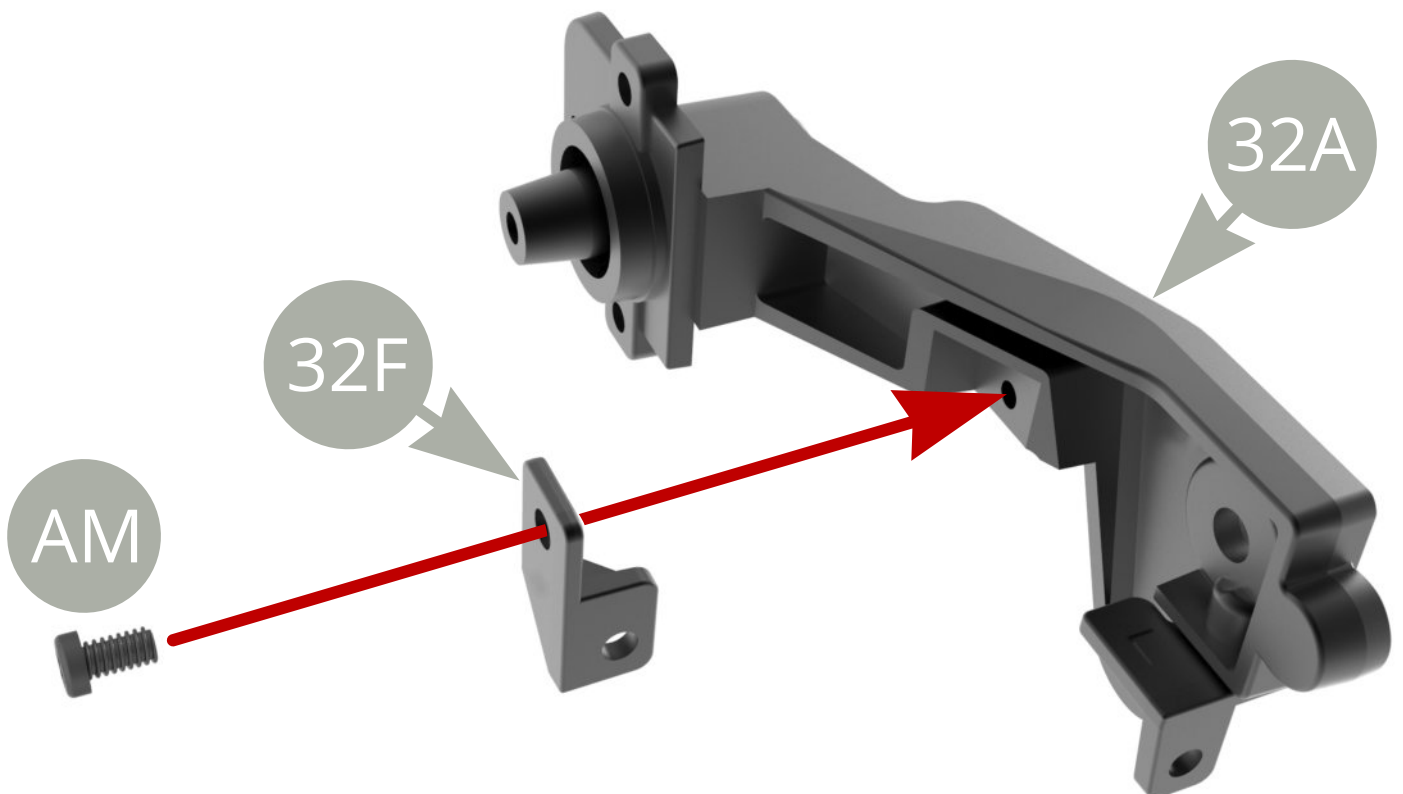

Fit **32F Brake hydraulic hose holder** to **32A Rear axle left trailing arm** and fix with **AM screw** .

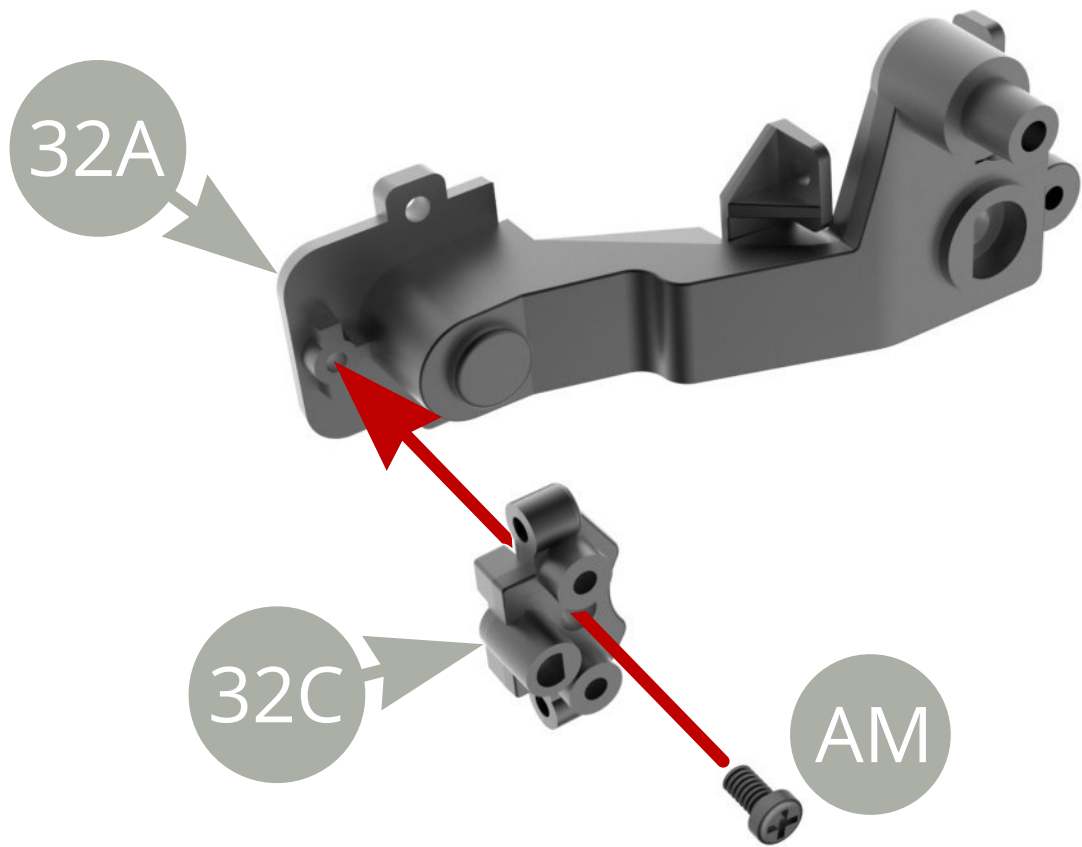

Fit **32C Caliper mounting bracket** to **32A Rear axle left trailing arm** and fix with **AM screw** .

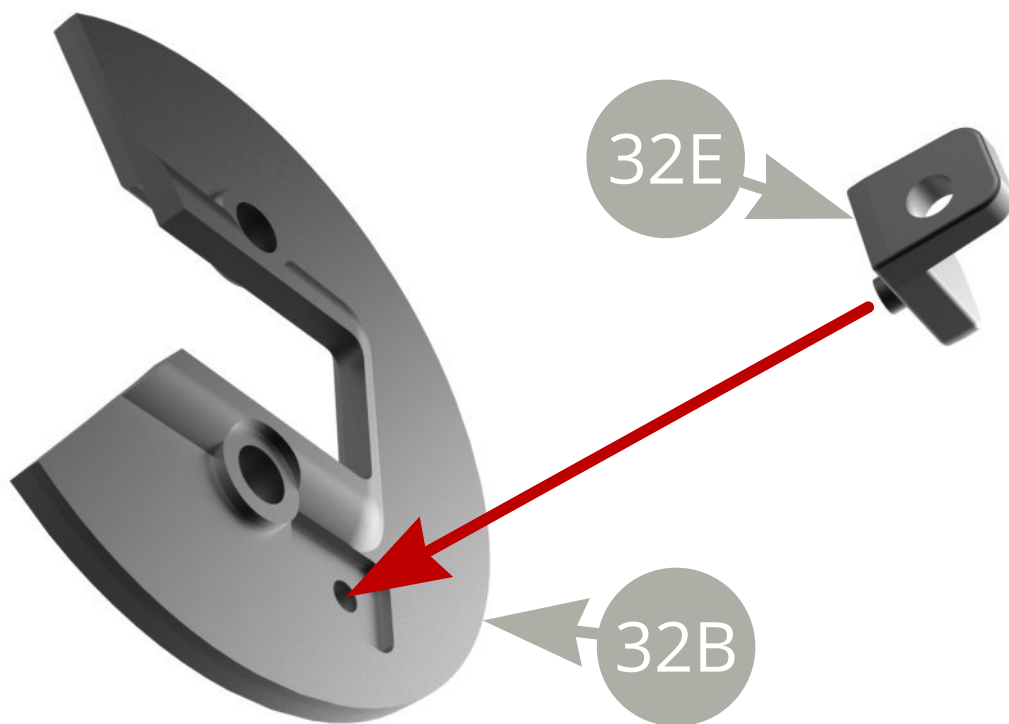

Fit **32E Brake hydraulic hose holder** to **32B Brake dust shield** .

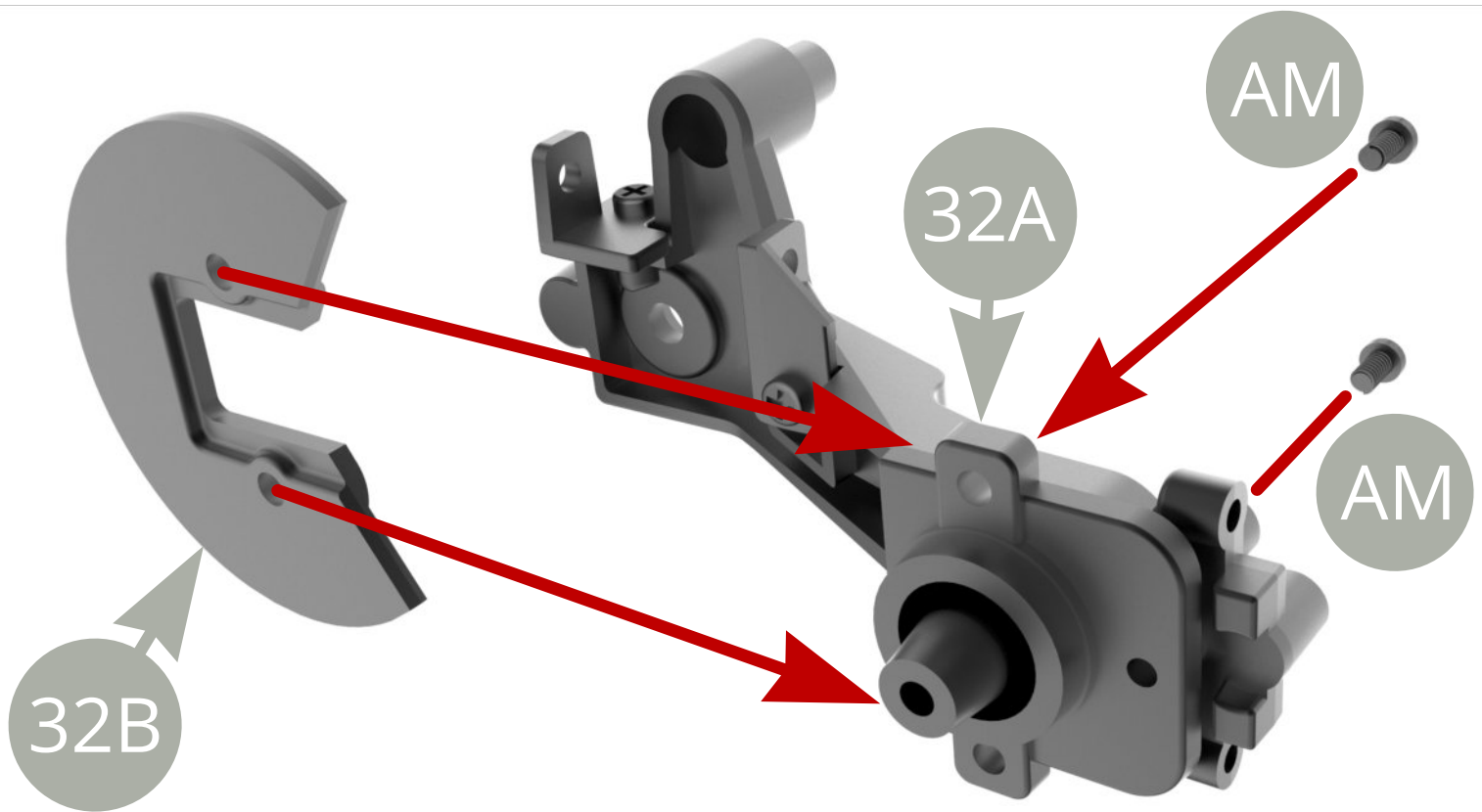

Slide **32B Brake dust shield** to **32A Rear axle left trailing arm** , aligning and fixing with two **AM screws** .

Final views .



Assembly drawing .

